

Unique Modulair Design

Falling Film water chiller



Falling Film water chiller

- new Modulair Design
- very fast delivery times
- dimensions 1,6 x 0,85 x 2,3m (l x w x h)
- capacity 700 kW
- delivery according PED (Test pressure 25 bar)

Specifications

- refrigerants: NH3, R404A, R507, R134A, R22
- pump or flooded operation
- direct expansion (DX) for Freon
- water outlet temperature 0,5°C
- high heat transfer values and low (no) pressure drop
- easy to clean because of removable water distribution
- standard tank: 1,7 x 1,5 x 0,75 (l x w x h, 50mm insulated)
- including hot /cold section for recirculation

 **Daussiny**
LASER WELDING



Operating Principle

Falling film water chillers are used to cool water close to the freezing point 0,5°C. The process water is evenly distributed over the evaporator plates and water flows as a thin water film over the outside of the evaporator. The cooled water is collected in a water tank.

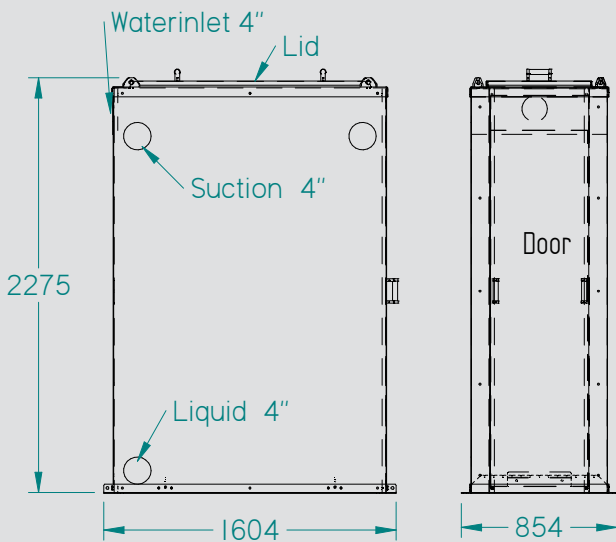

Applications

- continues production of large quantities of ice water (0,5°C)
- pre-cooling for ice banks (capacity increase)
- dairy industry
- meat and poultry processing
- fruit and vegetable processing
- concrete cooling

Advantages

- easy to clean
- fully laser welded , no gaskets
- low refrigerant content
- high heat transfer values
- low (no) pressure drop
- small footprint
- problem free operation with dirty water
- all stainless steel
- modular design
- fast delivery times

 **Daussiny**
LASER WELDING

Daussiny Laser Welding B.V.

Visiting address:

Handelskade Noord 1

7547 AV Enschede

PO Box 208

7500 AE Enschede

The Netherlands

Tel.: +31 53 20 30 670

Fax: +31 53 20 30 671

www.pillowplate.com

info@pillowplate.com